

**These operating instructions are for use on the construction site!**

**Caution** Please respect and refer to the operating instructions and safety regulations prior to operation!



Aluminium crane with trolley and hoist unit

### TABLE OF CONTENTS

Index		Page
1.	Definitions	2
2.	Safety Regulations	2
2.1	Utilisation As Directed	2
2.2	Safety Guidelines	2
2.3	Safety Measures	3
2.4	General Instructions	3
2.5	Assembly and Initial Operation	3
2.6	Liability	3
2.7	Regular Inspections	3
2.8	After Sales Service	3
3.	Specification	3
4.	Transport Of The Aluminium Crane	4
5.	Erection Of The Aluminium Crane	4
6.	Initial Operation And Control	5
6.1	Initial Operation	5
6.2	Duties Of The Crane Operator	5
6.3	Control	5
7.	Maintenance	5
8.	Repair	6
9.	Dismantling	6
10.	Legal Requirements	6
11.	Warranty And Liability	7
12.	EC Declaration of Conformity	8
13.	Spare Parts List	

## 1. Definitions

- Danger** indicates a dangerous situation. If it is not avoided, it will cause death or major injuries.
- Caution** indicates a dangerous situation. If it is not avoided, it can cause light or minor injuries or material damage. It also indicates incorrect use.

## 2. Safety Regulations

### 2.1 Utilisation As Directed

- The crane may only be used on even and solid ground. Otherwise the substructure of the legs must be able to take up the forces during crane operation.
- The crane may only be used to lift freely moveable loads.
- **Do not carry out** any alterations or modifications.
- The crane may only be equipped with a manual hoist.

**Danger** The following must be respected:

- **Do not transport people or animals, extremely hazardous!**
- **No personnel are allowed to remain under the load or within the danger area, extremely hazardous!**
- The aluminium crane may only be operated by a qualified crane operator.
- **Never exceed** the admissible maximum load of the crane or the hoist.
- **Do not pull** load to one side and do not drag load along the ground. Load must always be suspended in the true vertical position.
- **Do not allow** the load to break free, be pulled or dragged.
- Sudden movements and swinging of the load are not allowed.

### 2.2 Utilisation In Line With Safety Regulations

Although the WIMAG aluminium crane AK is technologically advanced in its construction, however, misuse or use against manufacturer's instructions may prove hazardous.

**Danger** The following must be respected:

- Prior to operation of the equipment the operator must read in full and understand both the operating instructions and the safety instructions, (as well as the operating and maintenance instructions of the hoist). These measures are necessary to guarantee human safety and safety within the working area. Only personnel who have been fully trained in its use can operate the equipment.
- Follow "Duties Of The Crane Operator".
- Always work with safety in mind and avoid risks.
- Report damages and defects of the crane to the relevant person immediately. Do not use the equipment until the damage has been repaired.
- **Never use** the equipment, if there are any defects which may affect the safety of the crane and the hoist. No opportunity should arise whereby it is possible to use the equipment prior to repair.
- **Do not remove** any nameplates from the crane. Replace illegible or damaged plates.
- The individual protective clothing must comply with safety regulations: safety clothes, safety helmet, protective gloves and shoes.
- An untidy work area increases safety hazards.

- **Do not allow** unauthorized personnel, particularly children, to remain within the working area.

### **2.3 Safety Measures**

**Caution** The following must be respected:

- Only personnel who have been fully trained or instructed in its use can operate the equipment. Respect legal minimum age!
- At regular intervals, check that work is being carried out safely.
- Keep to the intervals specified for periodic tests. Store test reports in the crane test book.
- Store the operating instructions within easy reach of where the equipment is used.

### **2.4 General Instructions**

- Safety Instructions and the Regulation BGV D6 "Cranes".
- National requirements.
- Regulations listed in the EC Declaration of Conformity.

### **2.5 Assembly And Initial Operation**

Assembly, initial operation, maintenance and repairs may only be carried out by qualified personnel.

- The company will accept no liability, unless original spare parts are used.
- **Do not carry out** any alterations or modifications.
- Additional structures must not affect the safety.
- When operating outdoors, do not allow hoist and travel drives to get wet.

### **2.6 Liability**

The company will accept no liability, unless assembly, operation, inspection and maintenance are carried out according to these operating instructions.

### **2.7 Regular Inspections**

Cranes must be examined by an expert at least once a year (BGG 905, Paragraph 3.2). All inspections must be initiated by the contractor.

### **2.8 After-Sales Service**

For the safety of the aluminium crane it is recommended that the manufacturer carries out all regular inspections and repairs.

## **3. Specification**

The WIMAG aluminium crane is a stationary crane designed for lifting and transporting loads on even and solid ground (the substructure, if any, must be able to take up the forces during crane operation) for indoor and outside use. The crane is delivered with a hand push trolley and can be equipped with a manual hoist (with load hook). All elements are joined by bolts or screws for fast assembly and dismantling.

The crane is equipped with four telescopic legs with foot plates. It can be easily erected by two people.

### Specification

Order No.	Model	Safe Working Load	Clearance Height LH min./max.	Total Height GH max.	Clearance Width LB max.	Weight
530 075	AK 750	750 kg	1.510 / 2.720 mm	1.870 / 3.080 mm	3.710 mm	85 kg
530 150	AK1500	1.500 kg	1.510 / 2.720 mm	1.870 / 3.080 mm	3.710 mm	105 kg

We also manufacture cranes according to customer's specification.

### 4. Transport Of The Aluminium Crane

The WIMAG aluminium crane is delivered folded for transport. Please ensure that all parts, especially the legs and the trolley are sufficiently safeguarded during transport.

The unit consists of the following elements:

- |                       |                         |
|-----------------------|-------------------------|
| 1 Beam (1)            | 2 Articulated heads (5) |
| 4 Telescopic legs (2) | 8 Bolts (6)             |
| 4 Foot plates (3)     | 4 Carrying handles (7)  |
| 1 Trolley (4)         |                         |

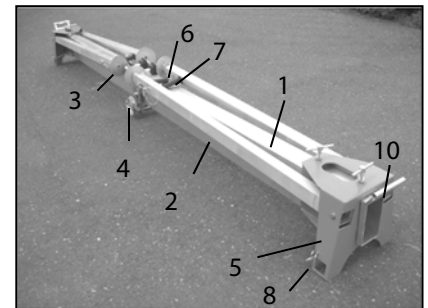

### 5. Erection Of The Aluminium Crane

The erection may only be carried out on even and solid ground in the following order:

- 5.1 The contractor must ensure that the crane is only erected and used on good firm soil and even ground. Otherwise the substructure for the four foot plates (3) must be able to take up the forces during crane operation.

- 5.2 Secure trolley (4) to prevent moving.

- 5.3 **Caution** Danger of overturning and danger of crushing injury!

Dismantle at one side of crane both carrying handles (7) and both bolts (8). Lift crane using the handle (10), move both legs up to the limit stop and replace and secure bolts (8). Now erect the other side.

- 5.4 If necessary, readjust span: release both tommy screws (9), move articulated head (5) and relock tommy screws (9).

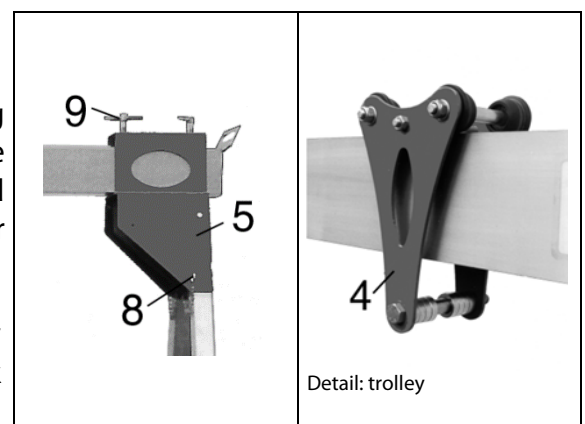

- 5.5 **Caution** Danger of overturning during height adjustment!

Adjust telescopic legs to the height required and secure each leg with bolts (6) and carrying handle (7).

- 5.6 **Caution** Danger of overturning without substructure!

On uneven and soft ground the substructure of the four foot plates must be professionally built: the crane must not swing and the beam must stay in an exact horizontal position!

- 5.7 Release locking device of the trolley (4) and fit in the manual hoist.

5.8 Read operating instructions of the manual hoist. Now, the crane is ready for operation.

## **6. Initial Operation And Control**

### **6.1 Initial Operation**

**When the safe working load of the crane exceeds 1.000 kg the initial operation may only be carried out by a fully trained crane operator and after the final inspection of a crane expert.**

Prior to the initial operation tighten all bolt and screw connections!

### **6.2 Duties Of The Crane Operator (BGV D6, §30)**

#### **Caution**

- The operator must ensure that
  - the load is safely attached,
  - no personnel remain within the hazardous area of the load.
- The operator must be able to see the entire working area, if not, seek assistance.
- During stormy weather suitable measures must be used to ensure that the crane will not tilt.

### **6.3 Control**

- After the assembly and the erection according to Paragraph 5 and the final inspection of the crane and the hoist (when the safe working load exceeds 1.000 kg) by a crane expert, the crane is ready for operation.
- The hoist is manually operated.
- **Do not pull** load to one side and do not drag load along the ground. Load must be always suspended in the true vertical position.
- Lifting: follow the operating instructions of the hoist! **Always lift load vertically, do not overload or sway the load!**
- Trolley: hand push trolley method. **Do not sway the load!**

## **7. Maintenance**

- **Follow the maintenance instructions of the hoist!**
- Protect the crane and the hoist from humidity.

### **Daily maintenance**

- Prior to operation, the functioning and the working condition of the crane, the hoist and the load handling device must be examined. Should there be any defects which may affect the safety of the equipment, the crane must only be used following repair!

### **Quarterly maintenance**

- Tighten screw connections, joints and bolts.
- Examine complete unit (e.g. replace missing screws, bolts, nuts, ...).
- Examine distortions (load hook, beam, legs, ...).

- Check surface finish and paint over, if necessary.

Maintenance work may only be carried out by qualified personnel. Any modifications may only be carried out by the manufacturer. Only use original spare parts for repairs.

## **8. Repair**

- Repairs may only be carried out by qualified personnel.
- Only original spare parts may be used, otherwise the warranty will become invalid.

## **9. Dismantling**

The dismantling is carried out as follows:

**Caution** Danger of crane tilting during the dismantling procedure!

- Remove hoist and prevent trolley (4) from moving.
- Adjust span as great as possible (see Para. 5.4).
- Completely push in legs and secure with bolt (6). Remove carrying handles (7).
- Release both bolts (8) of one articulated head (5). Lift crane using the handle (10), move both legs above the beam (1) and secure with carrying handle (7). Now fold the other side.
- Now the crane can be transported by two people.

## **10. Legal Requirements**

The prescription BGV D6 "Cranes", the operating instructions and the maintenance manual must be available and adhered to.

### **Extract from the Regulations for the Prevention of Accidents:**

Responsibility for the independent operation (crane operator) and maintenance (crane maintenance) may only be given to the following personnel:

1. must be at least 18 years old,
2. suitable personnel, both physically and mentally,
3. personnel who have been instructed in the operation and maintenance of the crane and whose qualification has been fully proven to the authorized personnel.

### **Inspections**

Manually-driven cranes whose carrying capacities exceed 1.000 kg must be examined by an expert prior to initial operation and after essential alterations prior to further operation.

### Regular Inspections

Depending on operating conditions, cranes with a carrying capacities exceeding 1.000 kg must be examined by an expert as required, however, this must be carried out at least once a year.

### Recording

The results of the inspections must be recorded in the supplied cranes test book (in case of carrying capacities exceeding 1.000 kg). The crane test book must be shown whenever requested.

It is recommended that all regular inspections and repairs are carried out by the manufacturer.

## **11. Warranty And Liability**

The warranty and the liability are no longer valid, if the equipment has not been assembled, installed, operated, checked and maintained according to these instructions.

Any doubts about instructions should be raised with the manufacturer prior to use.

Prior to every operation the user must ensure that

- the equipment is suitable for the intended operation,
- the functioning and the working condition of the equipment is examined,
- the loads are suitable to be handled.

Failures are to be reported in writing to the supplier immediately, at the latest two weeks following delivery. It is unacceptable for the contractor to repair failures or have them repaired by a third party, and then request to be reimbursed for the costs.

According to the manufacturer's general contract conditions the equipment is under warranty for a period of six months from the invoice date. Wearing parts are not covered by the warranty.

The manufacturer is not responsible for any damage occurring in the event of an installation error or insufficient training by a third party, negligence, misuse or excessive stress of the equipment.

It is within the responsibility of the contractor to check prior to operation the functional condition of the equipment, the suitability of the load to be handled as well as any damage to the load before and after transport/installation.

The manufacturer does not take responsibility for any additional claims, for instance, the right to compensation for damage not caused to the equipment itself.

## **WIMAG GmbH**

Brückenstraße 5

D - 63785 Obernburg am Main

Germany

Telefon +49 (0) 6022 / 68 47 0

Telefax +49 (0) 6022 / 68 47 50

gressbach@wimag.de

www.wimag.de

**12. EC Declaration Of Conformity** as defined by EC Machinery Directive 2006/42/EC

We hereby declare that the design and the construction of the equipment mentioned hereafter complies with the following Directive. This declaration will become invalid, if a modification of the equipment is carried out which has not been agreed with us as manufacturer.

The validity will also expire, if the equipment is not used as directed in accordance with manufacturer's relevant operating instructions and/or all regular inspections are not carried out according to DGUV 309-001 chapter 3.4.4.

Description	<b>WIMAG Aluminium Crane</b>
Model	<b>AK 750 / AK-1500</b>
Order No./Serial No.	530 075 / 530 150
Directives	EC Machinery Directive 2006/42/EC of 17 May 2006
Harmonised Standards	DIN EN ISO 12100 (Safety of Machinery) DIN EN 15 011 "Cranes – Bridge and Gantry Cranes"
National Standards:	DGUV Vorschrift 52 Cranes

As stipulated in Annex VII of the EC Machinery Directive the following documents are available for inspection:

- \* Operating instruction
- \* Production drawings
- \* Production plans
- \* Static verification
- \* Certification of welding EN 1090-2 EXC3

The CE symbol is marked on the equipment.

Obernburg, December 20<sup>th</sup> 2018

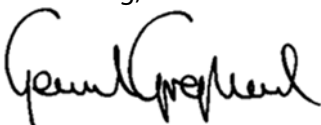

Gerhard Greßbach  
(Dipl. Ing.)

WIMAG GmbH  
Brückenstraße 5  
D-63785 Obernburg



## E 530 SPARE PARTS LIST

## Aluminium Crane AK 750

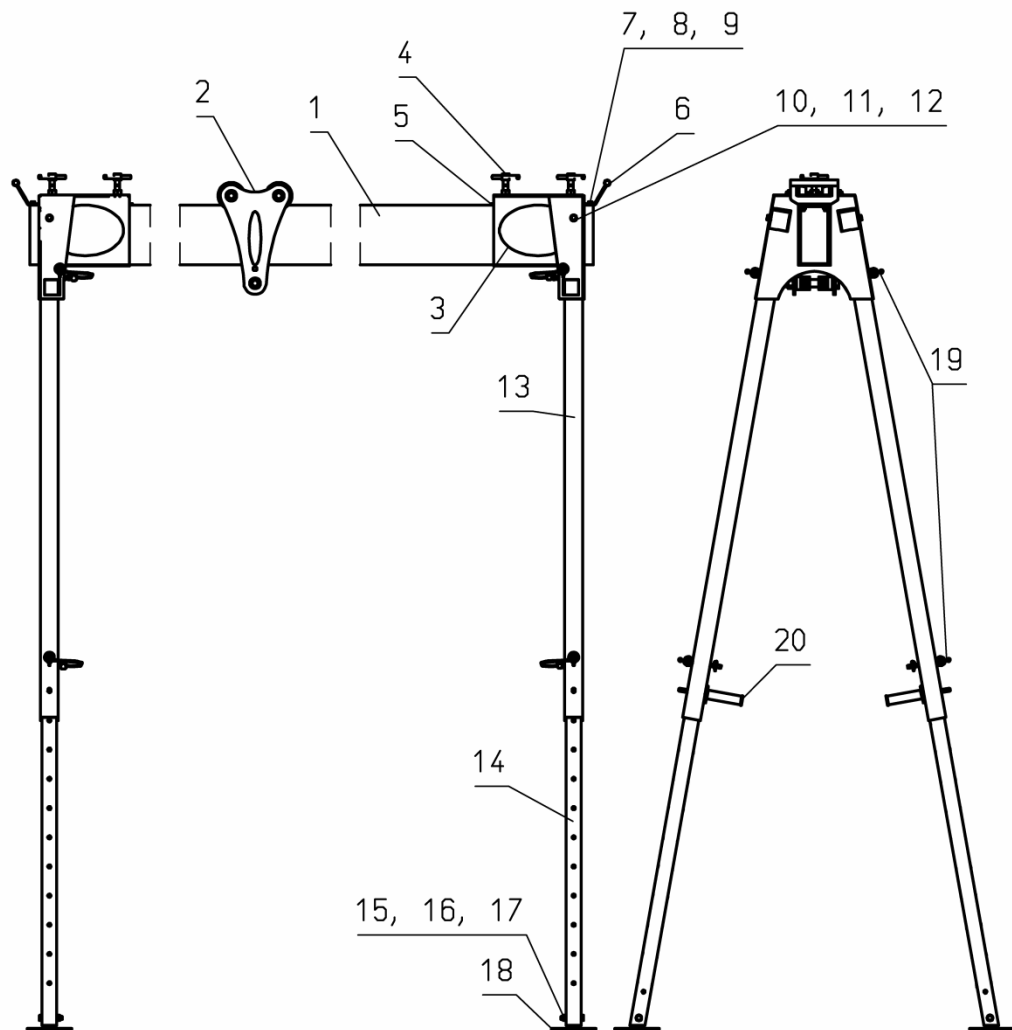

Item No.	Description	Aluminium Crane AK 750 530 075		
		Unit	Order No.	Price €/Unit
1	Beam	1	047 054	
2	Trolley	1	047 025	
3	Beam linkage head	2	048 601	
4	Tommy screw	4	050 429	
5	Pressure plate	4	048 610	
6	Handle	2	047 035	
7	Hexagonal head cap screw	4	050 239	
8	Hexagonal nut	4	051 101	
9	Washer	8	051 503	
10	Hexagonal head cap screw	4	050 024	
11	Hexagonal nut	4	051 102	
12	Washer	8	051 504	
13	Square section LO	4	048 616	
14	Square section LU static	4	048 718	
15	Hexagonal head cap screw	4	050 022	
16	Hexagonal nut	4	051 102	
17	Washer	8	051 504	
18	Foot	4	048 488	
19	Bolt	8	047 055	
20	Handle	4	048 623	

## E 530 SPARE PARTS LIST

## Aluminium Crane AK 1500

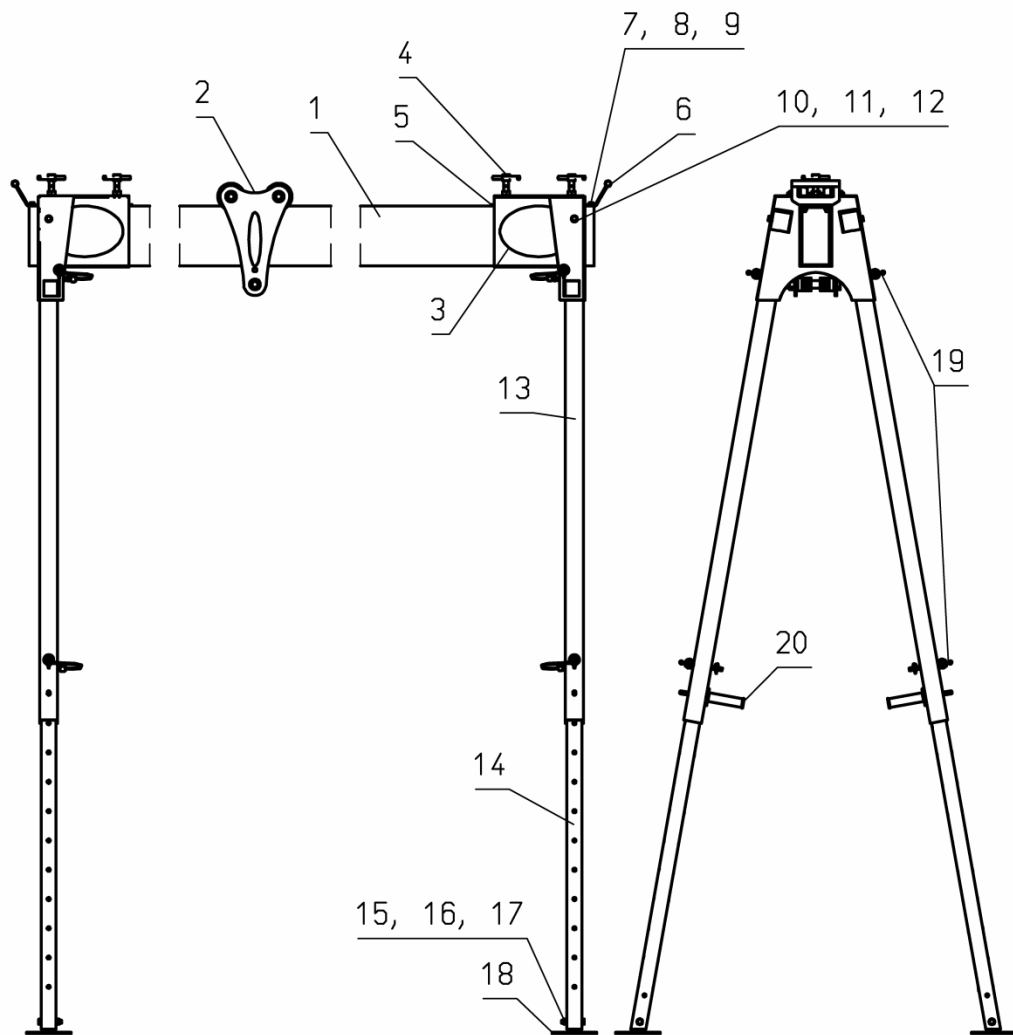

Item No.	Description	Aluminium Crane AK-1500 530 150		
		Unit	Order No.	Price €/Unit
1	Beam	1	047 341	
2	Trolley	1	047 340	
3	Beam linkage head	2	048 601	
4	Tommy screw	4	050 429	
5	Pressure plate	4	047 273	
6	Handle	2	047 035	
7	Hexagonal head cap screw	4	050 239	
8	Hexagonal nut	4	051 101	
9	Washer	8	051 503	
10	Hexagonal head cap screw	4	050 024	
11	Hexagonal nut	4	051 102	
12	Washer	8	051 504	
13	Square section LO	4	048 616	
14	Square section LU static	4	048 718	
15	Hexagonal head cap screw	4	050 022	
16	Hexagonal nut	4	051 102	
17	Washer	8	051 504	
18	Foot	4	048 488	
19	Bolt	8	047 055	
20	Handle	4	048 623	